

ECOWATER
SYSTEMS®



Your Water. Perfected.

Let us

Perfect

your water and

Protect

your family.

ERO 375

ECOWATER REVERSE OSMOSIS – DRINKING WATER SYSTEM

Reverse Osmosis Drinking Water System

Reverse Osmosis (RO) drinking water systems provide high-quality water for worry-free drinking or cooking. This state-of-the-art filter will improve the quality of water from wells or municipal water supplies.

Here's How an RO Works:

- 1 Household water is directed through a prefilter for filtration to remove sediment, chlorine taste and odor, and particulate matter.
- 2 The water is then forced, by pressure, through a semi-permeable membrane where a high percentage of the dissolved solids, etc. are rejected and flushed to the drain.
- 3 Filtered water is reserved in the storage tank until needed. An activated carbon absorption block filter that removes tastes and odors polishes the water immediately before going to the faucet.

Features:

- Industry rated, 50 gallons per day membrane production rate, (actual production rate will vary depending on water usage and conditions).
- The filters are enclosed for cleanliness and ease of replacement.
- Changing filters does not require turning off the water, a simple 1/4 turn of the filter shuts off the water and the filter is released at the same time.

Options:

- Unique and elegant chrome or brushed nickel faucet styles.
- Optional electronic faucet indicates when filters and membrane need to be replaced.
- System is expandable if additional filters need to be added.
- Additional filter selections are available, including higher capacity sediment, or a Volatile Organic Compound (VOC) rated filter.
- The membrane can be upgraded to a 75 gallon per day membrane.
- Adaptor kits are available to easily add a permeate pump system, which provides improved flow rates at the faucet.
- Booster pump system available in applications where home pressure can drop below 40 PSI.



Removes
99.3%
Lead

BPA-Free
System



OPTIONAL
Electronic Monitoring
Faucet Base

 Designed, Engineered &
Assembled in the U.S.A.

ecowater.com

ERO 375

ECOWATER REVERSE OSMOSIS DRINKING WATER SYSTEM

DIMENSIONS

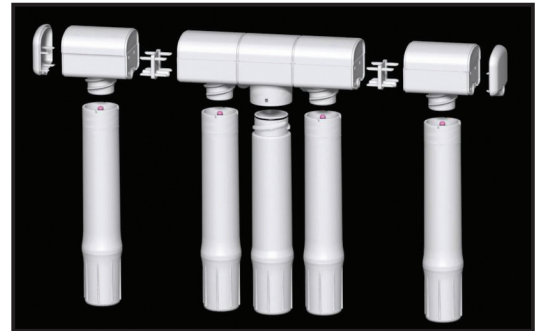
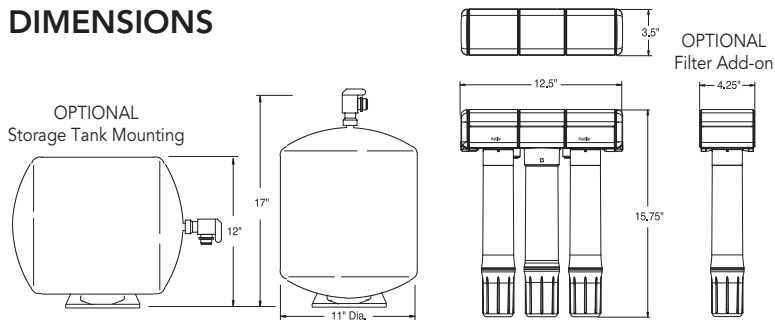

SPECIFICATIONS

	ERO 375
Feed water pressure (min.-max.)	40-100 psi
Feed water temperature (min.-max.)	40-100°F/4-38°C
Maximum Total Dissolved Solids (TDS)	2,000 ppm
Membrane percent rejection of TDS	92%
System product water production rate (gal. per day)*	17.4
Feed water pH limits	4-11 pH
Maximum iron	0
Maximum hydrogen sulfide	0
Type of membrane	thin film composite
Prefilter (sediment/chlorine)	block carbon
Postfilter (taste and odor)	block carbon
Optional:	
VOC filter	block carbon
Sediment filter	polypropylene fibers
High-flow membrane	thin film composite
Permeate pump adaptor	
Storage tank capacity	3.1 gal.
Automatic shut off valve	yes
Shipping weight	22 lbs.

*Tested to NSF/ANSI Standard 58.

ERO 375: For municipal and well water supplies. Chlorine must not exceed 2.0 ppm.

WARRANTY

- Five years on the reverse osmosis drinking water system for defects in material and workmanship, and 10 years on the storage tank.
- Exclusions to five years; one year on reverse osmosis membrane, and three years on faucet and electronics.
- The service life of the membrane and filter cartridges is dependent on the feedwater quality. Filters are not covered by the warranty.



Your Water. Perfected.

This drawing illustrates some of the customizable filter connection options the ERO 375 has to offer. Additional filter(s) may be added on to either side of standard unit.

- Optional sediment filter available
- Optional NSF Certified VOC* filter available

*VOC = Volatile Organic Compounds, 53 compounds in all, including MTBE, Atrazine, Benzene, Carbon Tetrachloride, 2,4-D, Toluene, Trihalomethanes, and Xylenes

Typical impurities reduced by an EcoWater Reverse Osmosis Drinking Water System Model ERO 375 TFC System.

- | | |
|----------------------------------|--------------------------|
| • Ammonium ¹ | • Fluoride |
| • Arsenic | • Lead |
| • Barium | • Magnesium ¹ |
| • Bicarbonate ¹ | • Nitrate/Nitrite |
| • Bromide ¹ | • Radium 226/228 |
| • Cadmium | • Selenium |
| • Chloride ¹ | • Sodium ¹ |
| • Chromium (Hex) | • Sulfate ¹ |
| • Chromium (Tri) | • Tannin ¹ |
| • Chlorine Taste & Odor | • TDS |
| • Copper | • Turbidity |
| • Cysts (Giardia/Cryptosporidia) | • Zinc ¹ |

Tested and Certified to NSF/ANSI Standard 58 by NSF International.

Rated at 50 psi, 77 F, 750 ppm/TDS, product to storage tank.

Product water produced, amount of waste water and percent rejection will vary with changes in pressure, temperature and total dissolved solids.

¹Tested by Spectrum Labs, Inc. a state certified testing laboratory.

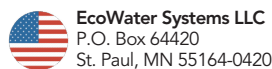

EcoWater Systems LLC
P.O. Box 64420
St. Paul, MN 55164-0420



EcoWater Canada Ltd.
5240 Bradco Blvd.
Mississauga, Ontario
Canada L4W 1G7



EcoWater Systems Europe N.V.
Geelseweg 56 2250 Olen
Belgium



Kunshan EcoWater Systems Co. Ltd.
483 San Xiang Rd.
Kunshan, Jiangsu Province, PRC 215335