

# ECR 3502

EcoWater Series • Water Conditioner



Clean water.  
Green future.

## The Latest Technology for Water Treatment

- 1 Bypass Valve (optional)**  
Brass-free and lead-free bypass valve lets you manually bypass the system.
- 2 Patented Electronic Digital Demand Module**  
Solid-state electronics record usage patterns and control regeneration frequency based on predicted needs. Full menu-driven options.
- 3 Full One-Inch Riser**  
One-inch diameter for increased flow rates, which ensures that household demand is adequately met.
- 4 Multi-Wrap Reinforced Resin Tank**  
High Density Polyethylene (HDPE) liner with an epoxy fiberglass composite winding. Doesn't deteriorate, rust, or corrode.
- 5 Self-Cleaning Distributors**  
Distributors exhibit excellent flow rates and are cleaned automatically by counter-current water pressure.
- 6 Positive-Action Brine Valve**  
Snap-together construction eliminates use of solvents that may contaminate water. Positive action helps prevent overfilling.
- 7 Patented Stratified Resin Bed**  
Patented mix of stratified resins provides superior filtration and iron removal without sacrificing flow rate capability.
- 8 Washed Quartz Underbedding**  
Washed quartz doesn't impart hardness into softened water and allows for more powerful "piston effect" during counter-current cycles.
- 9 HydroLink™ Remote (patent pending)**  
Two-way remote technology that makes it possible to control and monitor the Series 3500 water conditioner from anywhere in the home.

### Patented Six/Eight-Cycle Valve with Easy-Clamp Ring and Patented Teflon® Discs

### 24-Volt Transformer – ENERGY STAR® qualified

### Barium and Radium

This softener has been tested and certified by NSF International and WQA against NSF/ANSI Standard 44 for the reduction of Barium and Radium 226/228.

### Patented Exclusive Features

- Teflon Disc Valve
- Electronics
- Design
- Remote
- Salt Level Monitor
- Stratified Resin Bed



ECOWATER  
SYSTEMS®



A Marmon Water /  
Berkshire Hathaway Company

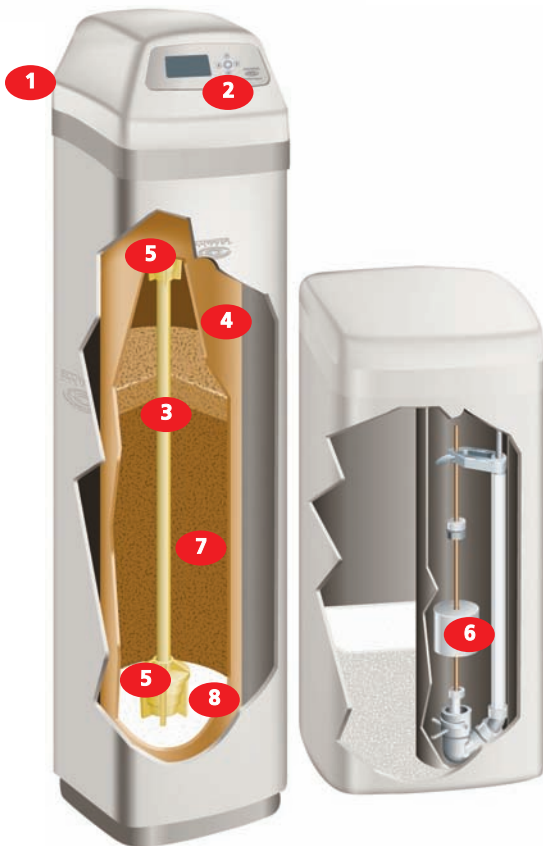

Series 3500  
HydroLink™ Remote



Tested to comply  
with FCC Standards  
IC3590A-7695.

\*Teflon is a registered trademark of DuPont.

ECOWATER.CA

# ECR 3502

## Specifications

|  | ECR 3502R30                 | ECR 3502R40                 | ECR 3502R50S                 | ECR 3502R70                   |
|--|-----------------------------|-----------------------------|------------------------------|-------------------------------|
| Efficiency (gr. / lb.)                                       | 5,160                       | 5,150                       | 5,110                        | 5,310                         |
| Rated Softening Capacity<br>(Grains @ lb. Salt Dose)         | 8,300 @ 1.6<br>25,000 @ 6.4 | 11,300 @ 2.2<br>33,00 @ 8.5 | 23,000 @ 4.5<br>40,800 @ 9.9 | 32,000 @ 6.2<br>57,600 @ 12.8 |
| Hardness Capacity (gr. @ max. lb. salt dose)                 | 30,200 @ 11.3               | 40,100 @ 14.8               | 71,500 @ 19.3                | 71,500 @ 19.3                 |
| Certified Flow Rate (gpm @ psi)                              | 11 @ 8                      | 12 @ 13                     | 12 @ 11                      | 12 @ 11                       |
| Intermittent Flow Rate (gpm @ psi) <sup>1</sup>              | 16.5 @ 15                   | 13.6 @ 15                   | 20 @ 15                      | 17.0 @ 15                     |
| Intermittent Flow Rate (gpm @ psi) <sup>1</sup>              | 25.8 @ 30                   | 21.6 @ 30                   | 30 @ 30                      | 22.0 @ 30                     |
| Patented Resin Bed #5,464,532 (lbs.)                         | 47                          | 63                          | 109                          | 109                           |
| Quartz Gravel Base (lbs.)                                    | 10                          | 10                          | 12                           | 12                            |
| Maximum Water Hardness (grains per gallon)                   | 60                          | 75                          | 125                          | 125                           |
| Maximum Clear Water Iron (ppm-Fe) <sup>2</sup>               | 12                          | 15                          | 15                           | 15                            |
| Approximate Water Used Each Regeneration (gal.) <sup>3</sup> | 36                          | 51                          | 104                          | 104                           |
| Salt Storage Capacity (lbs.)                                 | 300                         | 300                         | 300                          | 300                           |
| Supply Water Pressure Limits (psi) <sup>4</sup>              | 20 – 125                    | 20 – 125                    | 20 - 125                     | 20 - 125                      |
| Supply Water Temperature Limits (°F)                         | 40 – 120                    | 40 – 120                    | 40 - 120                     | 40 - 120                      |
| Ambient Temperature Range (°F)                               | 35 – 150                    | 35 – 150                    | 35 - 150                     | 35 - 150                      |
| Plumbing Connection Provided (inches)                        | 1 to 1 <sup>1/2</sup>       | 1 to 1 <sup>1/2</sup>       | 1 to 1 <sup>1/2</sup>        | 1 to 1 <sup>1/2</sup>         |
| Electrical Rating (transformer provided)                     | 24V-50/60Hz                 | 24V-50/60Hz                 | 24V-50/60Hz                  | 24V-50/60Hz                   |

<sup>1</sup>Intermittent flow rate does not represent the maximum service flow rate used for determining the conditioner's rated capacity and efficiency. Continuous operation at flow rates greater than the certified flow rate may affect capacity and efficiency performance. The validity of these flow rates is verified by NSF.

<sup>2</sup>Increased amounts of clear water iron can reduce conditioners efficiency. Refer to owner's manual for details. Wisconsin requires additional treatment if water supply contains greater than 5 ppm clear water iron. <sup>3</sup>When operated at 35 psi water pressure <sup>4</sup>Maximum pressure for Canadian use is 7.0 Kg/cm<sup>2</sup>

## Dimensions

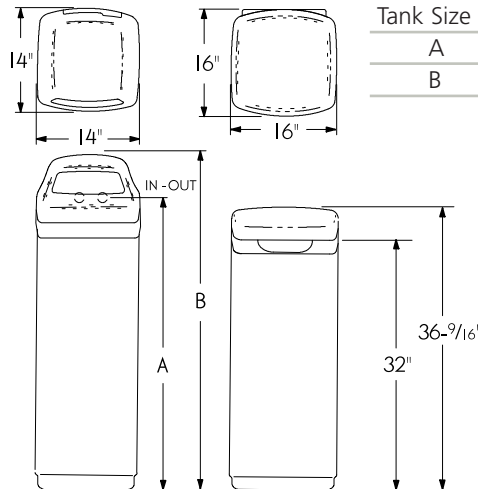

|                         | ECR 3502R30    | ECR 3502R40    | ECR 3502R70    |
|-------------------------|----------------|----------------|----------------|
| Nominal Resin Tank Size | 10" Dia. x 35" | 10" Dia. x 47" | 10" Dia. x 54" |
| A                       | 39.5"          | 51.3"          | 57.1"          |
| B                       | 44.8"          | 56.6"          | 62.2"          |

Your Authorized EcoWater Dealer:



EcoWater Canada Ltd. 5240 Bradco Blvd. Mississauga, Ontario Canada L4W 1G7

850759

05/09

Printed in Canada

EcoWater Canada Ltd.

**ECOWATER.CA**